

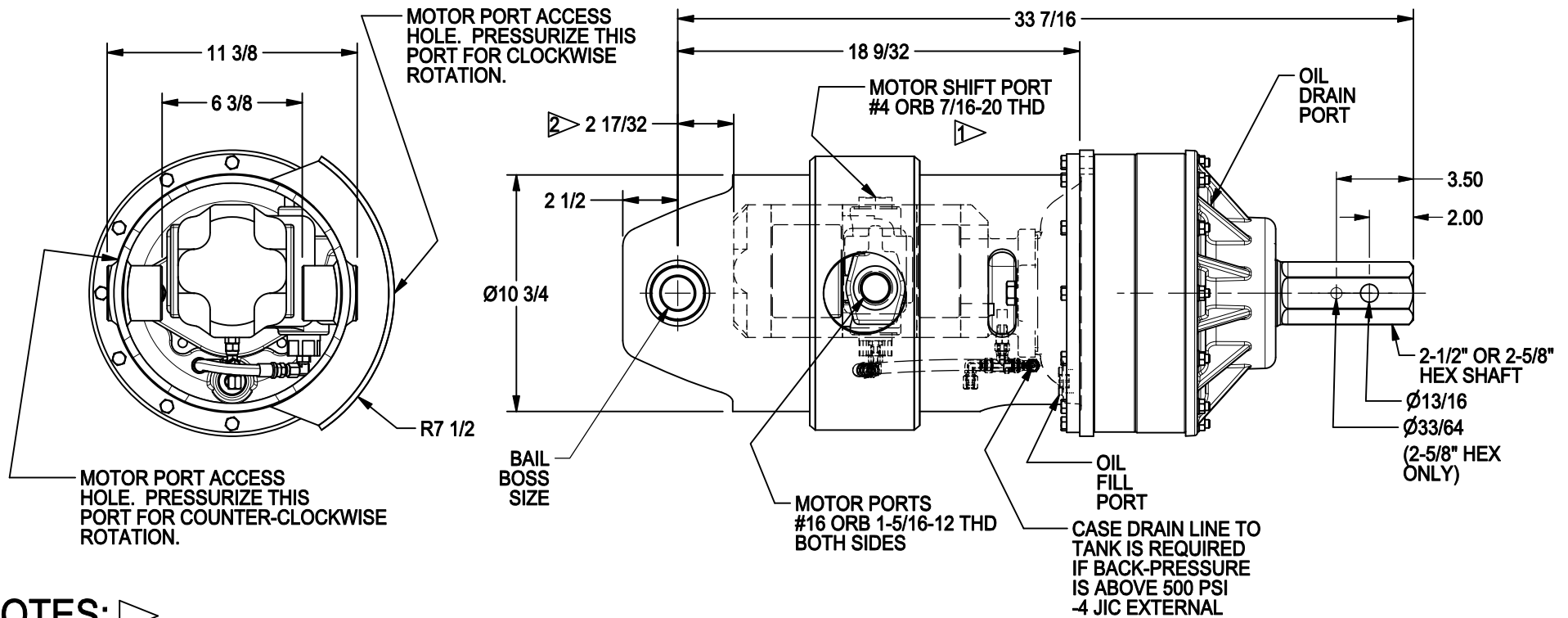

78 SERIES DRIVE HEAD

Up to 12,000 ft-lb (16,270 N-m), 2-speed, shift-on-the-fly.
 Typical Applications: Utility and Construction Industries.

(913) 782-1238 (Tel)
 (913) 782-4206 (Fax)
 Sales@Eskridgeinc.com
 www.Eskridgeinc.com
 FORM: PS78-DD
 SHEET 1 OF 3



NOTES: ▷

- 1 WITH NO PRESSURE TO SHIFT PORT, THE MOTOR OPERATES IN HIGH-SPEED, LOW-TORQUE MODE. TO SHIFT THE DRIVE HEAD TO LOW-SPEED, HIGH TORQUE MODE, APPLY A PRESSURE OF 300 PSI (MINIMUM), 2500 PSI (MAXIMUM), TO THE SHIFT PORT. PRESSURE MUST BE MAINTAINED TO KEEP DRIVE HEAD IN LOW-SPEED, HIGH-TORQUE. MOTOR MAY BE SHIFTED TO HIGH-SPEED OR LOW-SPEED WHILE TURNING OR WHILE STOPPED. MOTORS ARE AVAILABLE WHICH OPERATE NORMALLY IN LOW-SPEED, HIGH-TORQUE MODE AND ARE SHIFTED TO HIGH-SPEED, LOW-TORQUE MODE; CONSULT ESKRIDGE SALES FOR DETAILS.
- 2 SUBJECT TO CHANGE WITH DIFFERENT MOTOR.
- 3 VALUES ARE SHOWN IN INCHES.

SHOWN ABOVE WITH "STANDARD BAIL".
 ROTATED BAIL SHOWN BELOW.

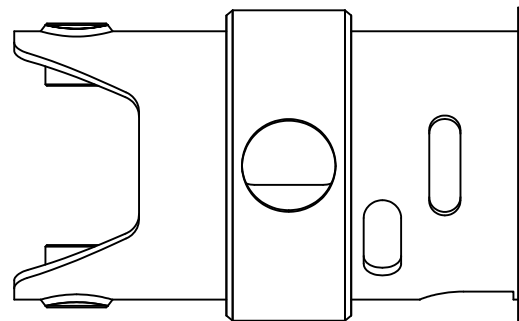



78 SERIES DRIVE HEAD

Up to 12,000 ft-lb (16,270 N-m), 2-speed, shift-on-the-fly.
 Typical Applications: Utility and Construction Industries.

(913) 782-1238 (Tel)
 (913) 782-4206 (Fax)
Sales@Eskridgeinc.com
www.Eskridgeinc.com
 FORM: PS78-DD
 SHEET 2 OF 3

Performance Ratings

Maximum Intermittent Output Torque: TO 12,000 FT-LB (16,272 N-m)
 Shaft Pressure Load Rating: 19,000 lb (8,600 kg)
 Shaft Pullout Load Rating: 21,000 lb (9,500 kg)
 *Shaft side loading not recommended.
 Maximum Input Speed: 3,000 RPM
 Maximum Operating Ambient Temperature: 110° F (43° C)
 Minimum Operating Ambient Temperature: -20° F (-28° C)

Oil Capacities

7835 & 7848
6.5 PINTS
3.1 LITERS

ALL UNITS WITH MOTORS SHIPPED WITH OIL
 Use EP or API GL-5 Designated Lubricants

Motor Mount Dimensions

PILOT DIMENSIONS	BOLT CIRCLE
SAE 'C' Ø5.001/5.004	2X 5/8-11 UNC-2B ∇1 ON Ø7.125 B.C.

Motor Specifications:

Two Speed Hydraulic Gear Motors
 Maximum System Pressure: 2500 psi (172 bar)
 For Manual Cab Mounted Shifting,
 ask about our Shifter Valve, 01-308-0130.
 Motors are internally drained and generally don't require a case
 drain. If backpressure exceeds 500 psi a case drain is required.

Approximate Unit Weight

With Motor: 370 lb (168.2 kg)

Ordering Information

Example part number: 7848-65F58R

MODEL	OUTPUT SHAFT	BAIL BOSS	MOTOR SUPPLIER	MOTOR PART NUMBER	OPTIONS
7848	6	5	F	58	R
7835 35:1 GEAR RATIO 9,500 FT-LB TORQUE: LOW SPEED 2,800 FT-LB TORQUE: HIGH SPEED RPM DEPENDANT ON MOTOR SELECTION	5- 2 1/2" HEX 6- 2 5/8" HEX	4- Ø1 1/4 5- Ø1 1/2	F- FACTORY U- USER	58- 7848 12,000 ft-lb LSHT 3,300 ft-lb HSLT 7835 9,000 ft-lb LSHT 2,900 ft-lb HSLT 60- 7835 9,630 ft-lb LSHT 3,000 ft-lb HSLT	R- ROTATED BAIL 90° FOR BACKHOE AND EXCAVATOR USE BLANK- STANDARD BAIL FOR MOST UTILITY DIGGER DERRICK TRUCKS
7848 48:1 GEAR RATIO 12,000 FT-LB TORQUE: LOW SPEED 3,200 FT-LB TORQUE: HIGH SPEED RPM (22.36-LOW SPEED, 55 RPM HI SPEED) USE MOTOR CODE 58 ONLY					



78 SERIES DRIVE HEAD

Up to 12,000 ft-lb (16,270 N-m), 2-speed, shift-on-the-fly.
Typical Applications: Utility and Construction Industries.

(913) 782-1238 (Tel)
(913) 782-4206 (Fax)
Sales@Eskridgeinc.com
www.Eskridgeinc.com
FORM: PS78-DD
SHEET 3 OF 3

7848 DRIVE HEAD WITH CODE 58 MOTOR

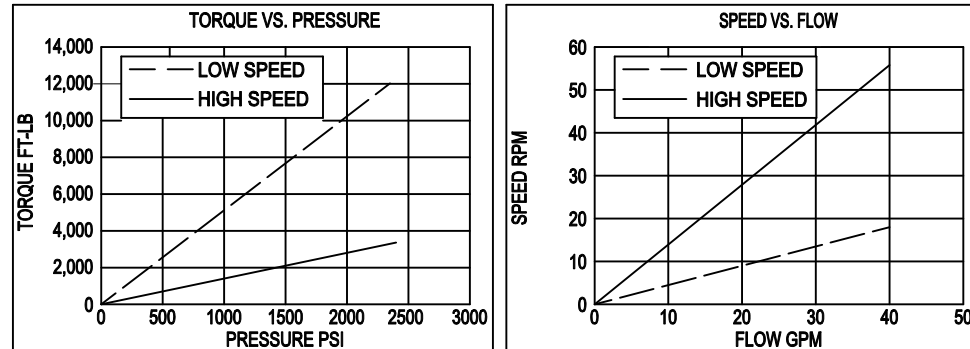

7835 DRIVE HEAD WITH CODE 58 MOTOR

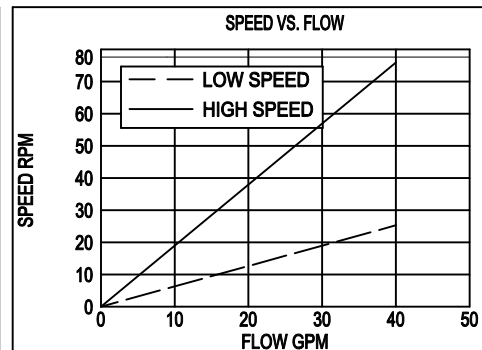
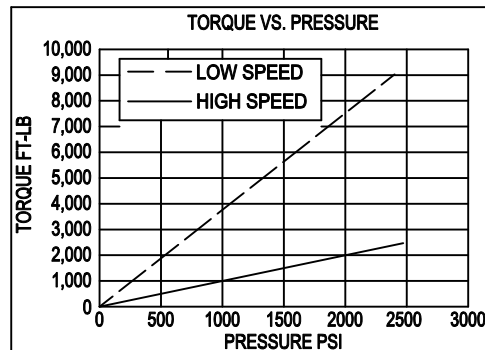

7835 DRIVE HEAD WITH CODE 60 MOTOR

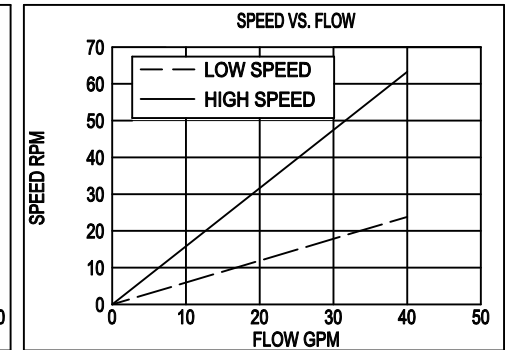
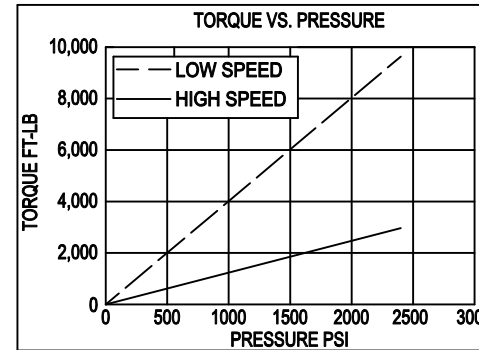

NOTES:

- * Starting torques are approximately 25% less than running torque.
- * Torque and speed charts are based on analytical calculations that use average gearbox and motor efficiencies.
- * System back pressure will reduce running torque proportionally.
- * Consult Eskridge Representative for Torque and Speed Charts for your specific application.

ESKRIDGE, INC. EXPRESSLY DISCLAIMS ANY IMPLIED WARRANTY OF MERCHANTABILITY OR FITNESS FOR ANY PARTICULAR PURPOSE FOR THE PRODUCTS SHOWN HEREIN.

Any claims based on or related to the products shown herein will be satisfied only by repair or replacement in Eskridge, Inc.'s sole discretion to the extent covered by Eskridge's Product Warranty. Eskridge, Inc. is not liable for incidental or consequential damage of any kind or nature that relate in any way to the products shown herein. For complete warranty information, please refer to Eskridge, Inc.'s Product Warranty that applies to the products shown herein and is incorporated by this reference as if fully set forth. A copy of Eskridge, Inc.'s Product Warranty can be obtained by writing Eskridge, Inc. at P.O. Box 875, 1900 Kansas City Road, Olathe, Kansas 66061