



77 SERIES HEAVY DUTY DRIVE HEAD

6,500 ft-lb (8,812 N-m) to 12,000 ft-lb (16,270 N-m) Maximum
Typical Applications: Utility and Construction Industries

(913) 782-1238 (Tel)
(913) 782-4206 (Fax)
Sales@Eskridgeinc.com
www.Eskridgeinc.com
FORM: PSS77-AA

Page 1 of 3

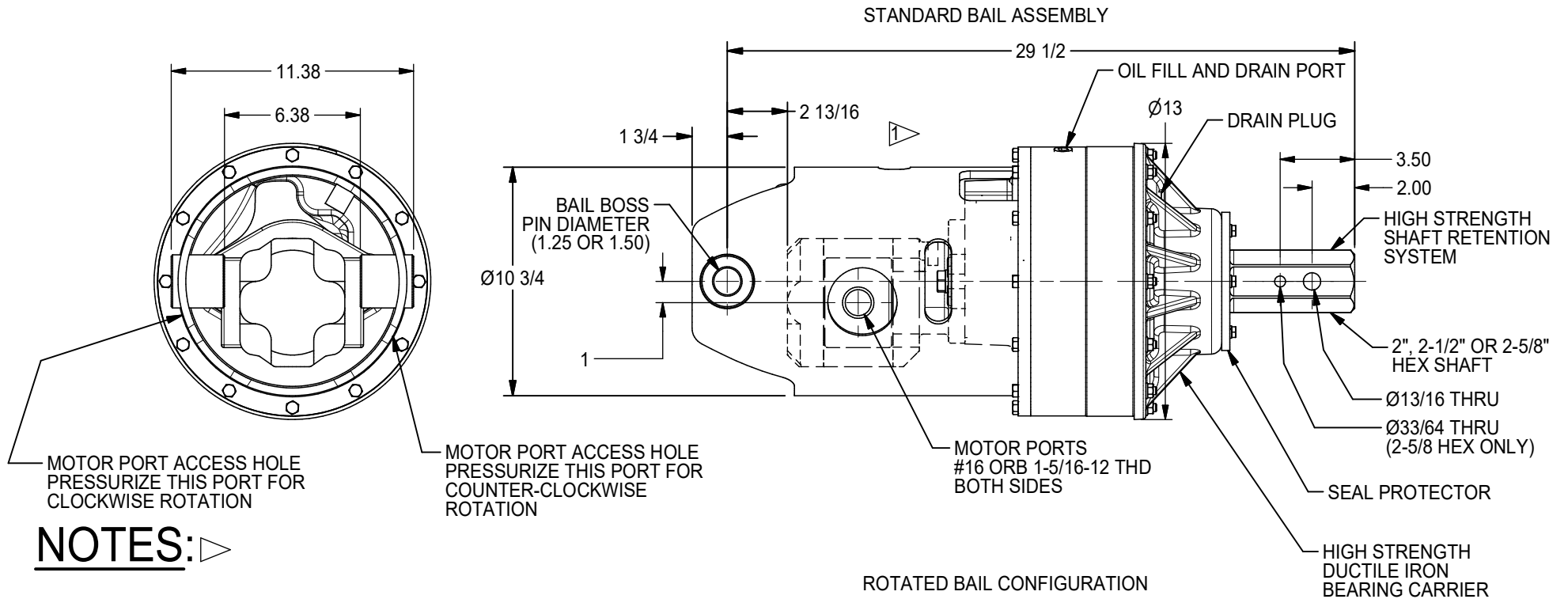

NOTES: ▷

1. SUBJECT TO CHANGE WITH DIFFERENT MOTORS.
2. VALUES ARE SHOWN IN INCHES.



77 SERIES HEAVY DUTY DRIVE HEAD

6,500 ft-lb (8,812 N-m) to 12,000 ft-lb (16,270 N-m) Maximum
Typical Applications: Utility and Construction Industries

(913) 782-1238 (Tel)
(913) 782-4206 (Fax)
Sales@Eskridgeinc.com
www.Eskridgeinc.com
FORM: PSS77-AA

Page 2 of 3

Performance Ratings

Maximum Intermittent Output Torque:	12,000 ft-lb (16,270 N-m)
Shaft Pressure Load:	19,000 lb (8,600 Kg)
Shaft Pullout Load:	21,000 lb (9,500 Kg)
*Shaft Side loading Not Recommended	
Maximum Input Speed:	3000 RPM
Maximum Operating Ambient Temperature:	110°F (43°C)
Minimum Operating Ambient Temperature:	-20°F (-28°C)

Consult your Eskridge representative to determine ratings for your specific application or configuration

Oil Capacities

77BA	77BC	77BD
6.5 PINTS	6.5 PINTS	6.5 PINTS
3.1 LITERS	3.1 LITERS	3.1 LITERS

ALL UNITS WITH MOTORS SHIPPED WITH OIL
Use EP or API GL-5 Designated Lubricants

Ordering Information
Example Part Number: 77BA-64F59R

Motor Mount Dimensions

PILOT DIMENSIONS	BOLT CIRCLE
SAE 'C' Ø5.001/5.004	2X 5/8-11 UNC-2B ∇1 ON Ø7.125 B.C.

Motor Specifications:

Single-Speed Hydraulic Gear Motors
Maximum System Pressure: 2500 psi (172 bar).
Motors are internally drained and generally don't require a case drain. Both the code '23' and code '59' motor are limited to 500 psi due to a high-pressure seal. If the back pressure exceeds this limit, a case drain is required.

Approximate Unit Weight

With Motor: 250 lb (113 kg)

MODEL	OUTPUT SHAFT	BAIL BOSS	MOTOR SUPPLIER	MOTOR PART NUMBER	OPTIONS
S77BA	6P	4	F	59	R
S77BA- 70:1 GEAR RATIO 23/59 MOTOR 12,000 FT-LB TORQUE 23 RPM		4- Ø1 1/4 5- Ø1 1/2	F- FACTORY U- USER	23- WINCH MOTOR* 6.38 CID 59- STANDARD MOTOR 6.38 CID	R- ROTATED BAIL 90° FOR BACKHOE AND EXCAVATOR USE
77BC- 46:1 GEAR RATIO 23/59 MOTOR 8,000 FT-LB TORQUE 35 RPM	5P- 2 1/2" HEX PLATE RETAINED 6P- 2 5/8" HEX PLATE RETAINED				
S77BD- 38:1 GEAR RATIO 23-59 MOTOR 6,500 FT-LB TORQUE 43 RPM				*A Winch Gear Motor can Operate Smoothly Down to 100 motor rpm. Typical Gear Motors Can Only be Operated Down to 350 motor rpm. Ideal for Machines with Flow Below 20GPM or for Anchor Installation.	



77 SERIES HEAVY DUTY DRIVE HEAD

6,500 ft-lb (8,812 N-m) to 12,000 ft-lb (16,270 N-m) Maximum
 Typical Applications: Utility and Construction Industries

(913) 782-1238 (Tel)
 (913) 782-4206 (Fax)
Sales@Eskridgeinc.com
www.Eskridgeinc.com
 FORM: PSS77-AA

Page 3 of 3

Torque and Speed Charts:

77BA With 23 OR 59 Motor

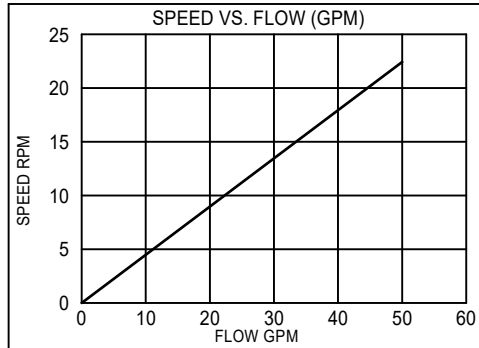
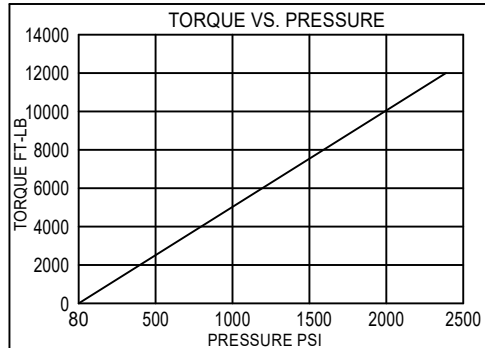

77BC With 23 or 59 Motor

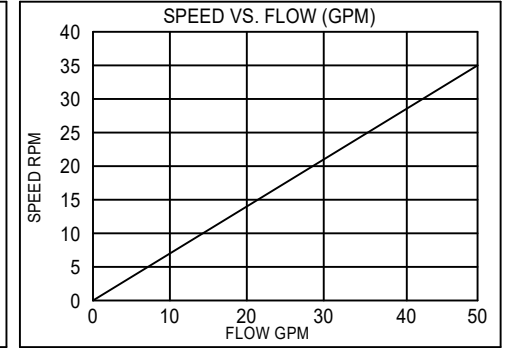
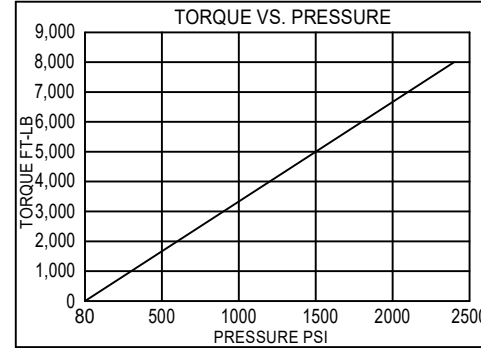

77BD With 23 or 59 Motor

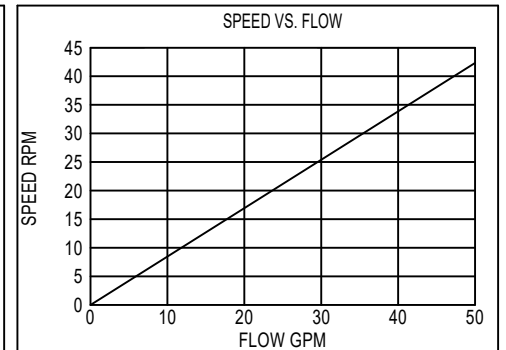
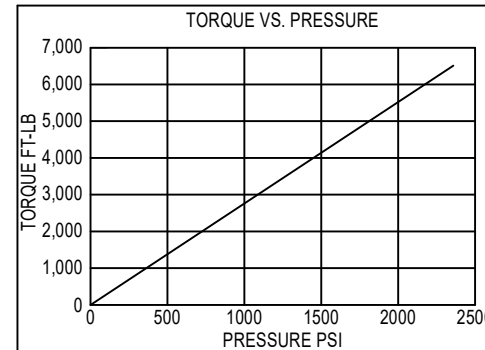

- * Starting torques are approximately 25% less than running torque.
- * Torque and speed charts are based on analytical calculations that use average gearbox and motor efficiencies.
- * System back pressure will reduce running torque proportionally.
- * Consult Eskridge Representative for Torque and Speed Charts for your specific application.

ESKRIDGE, INC. EXPRESSLY DISCLAIMS ANY IMPLIED WARRANTY OF MERCHANTABILITY OR FITNESS FOR ANY PARTICULAR PURPOSE FOR THE PRODUCTS SHOWN HEREIN.
 Any claims based on or related to the products shown herein will be satisfied only by repair or replacement in Eskridge, Inc.'s sole discretion to the extent covered by Eskridge's Product Warranty. Eskridge, Inc. is not liable for incidental or consequential damage of any kind or nature that relate in any way to the products shown herein. For complete warranty information, please refer to Eskridge, Inc.'s Product Warranty that applies to the products shown herein and is incorporated by this reference as if fully set forth. A copy of Eskridge, Inc.'s Product Warranty can be obtained by writing Eskridge, Inc. at P.O. Box 875, 1900 Kansas City Road, Olathe, Kansas 66061